

TPS-2 Portable Photosynthesis System

*Your research
partner for over
25 years*



Data Sheet

Overview

Since 1984, PP Systems has been recognized as a leader in the design and manufacture of photosynthesis measurement instrumentation for high level research. Currently, we have well over 1,000 portable photosynthesis systems in operation throughout the world and widely referenced in many prestigious scientific publications.

Our TPS-2 Portable Photosynthesis System features a high technical specification at an affordable price making it an ideal choice for basic research and teaching. The system operation and setup protocol is extremely user friendly. Although the main application for the system is leaf gas exchange, the TPS-2 main console can also be used as a high precision, stand-alone gas analysis system for measurement of CO₂ & H₂O in the lab or field.

Measurement Theory

Measurement of CO₂ uptake is the most commonly used and easiest method for determination of photosynthesis in plants. Using infrared gas analysis techniques, we can readily determine CO₂ concentrations to within 1 ppm and instantaneous, non-destructive measurements are possible. The TPS-2 passes a measured flow of air over a leaf sealed into a chamber called the "leaf cuvette". Using a "gas switching" technique, the TPS-2 first samples the CO₂ and H₂O of the air going to the cuvette (reference) and then the air leaving the cuvette (analysis). From the flow rate and the change in concentrations, the assimilation rate of CO₂ and transpiration rate of water can be determined. This technique is commonly referred to as the "open" system method of measurement and is the method employed by the TPS-2. Designed for use under the most demanding field conditions (high temperature and humidity, dust), the system is equipped with an internal, hydrophobic filtering system ensuring that all internal parts are fully protected.



TPS-2 Main Console and Leaf Cuvette

CO₂ & H₂O Measurement

The TPS-2 is a high precision instrument. It features a single, non-dispersive infrared gas analyzer for accurate measurement of CO₂. The gas analyzer includes an infrared source, a gold plated and highly polished sample cell and detector. The analyzer acts as an absorptiometer measuring only in the 4.26 μm waveband ensuring accurate, rapid and stable CO₂ results. The optical bench is thermostated and completely insulated to ensure accurate measurements under changing ambient temperatures. Our unique "Auto-Zero" facility ensures long term stability and accuracy of the CO₂ reading. A built-in, high precision humidity sensor measures H₂O. There are no moving parts and all readings are corrected for changes in temperature and pressure.

The TPS-2 system is capable of providing control of both CO₂ and H₂O in a series of preset steps from 0 to ambient. On-board, self-indicating desiccants are used to condition the CO₂ and H₂O air.

The TPS-2 is also capable of controlling CO₂ at higher concentrations if used with an external gas cylinder.



Self-indicating desiccants for analyzer zeroing and CO₂/H₂O control

Measurement Ranges

CO₂: 0-2,000 μmol mol⁻¹ (optimal)

CO₂: 0-9,999 μmol mol⁻¹ (max)

H₂O: 0-Dewpoint

For measurements at elevated CO₂ concentrations, the TPS-2 is factory calibrated up to 9,999 μmol mol⁻¹ as standard.

TPS-2 Flow Schematic

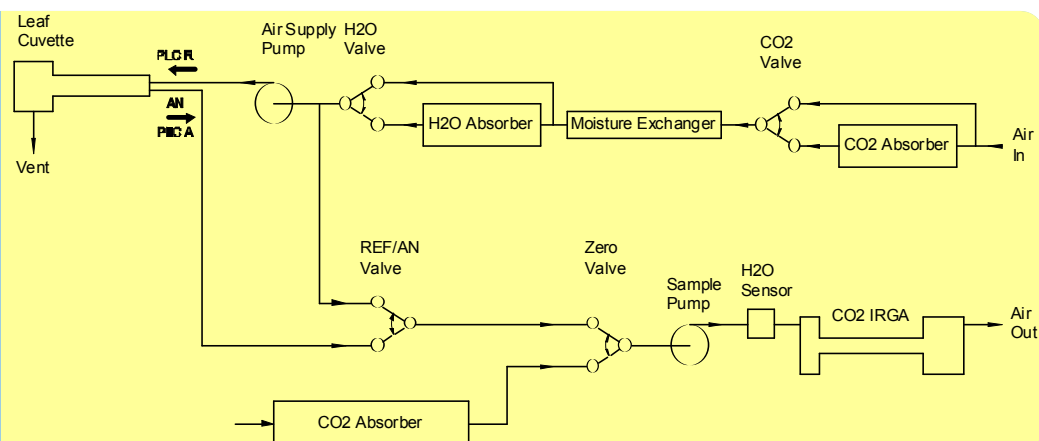

Leaf Cuvette

PP Systems is recognized globally as a specialist in leaf chamber design. All of our chambers are designed with carefully selected materials that minimize CO₂ and H₂O absorption/adsorption ensuring the most accurate leaf gas exchange results. The leaf cuvette is designed to couple close to the ambient.

The PLC4 (B) leaf cuvette features a miniature sensor for accurate measurement of PAR (Photosynthetically Active Radiation) and an air temperature sensor.



Close-up of PLC4 (B) leaf cuvette head

Optional Light Control

PP Systems offers an optional light unit (LED) featuring simple, manual control of cuvette light intensity in the range of 0-2,000 $\mu\text{mol m}^{-2} \text{s}^{-1}$. This is particularly useful for light response and A/Ci curves. If required, the light unit can be removed for ambient measurements. For A/Ci curves, the light source can remain at constant levels while CO₂ can be changed independently. The light unit can be powered directly by the TPS-2 (no external battery is required).



A custom designed field carrying case is supplied with each system as standard. It has pockets to safely store/transport the TPS-2 main console and leaf cuvette.



Technical Specification

Main Console

Analysis Method

Non-dispersive infrared, configured as an absolute absorptiometer with microprocessor control of linearization.

Measurement Range

CO₂: 0-2,000 $\mu\text{mol mol}^{-1}$ (Optimal Range)
0-9,999 $\mu\text{mol mol}^{-1}$ (Max. Range)

H₂O: 0-75 mb

Corrections are made for temperature, pressure and foreign gas broadening.

Precision (Absolute)

CO₂: < 1% at 300 ppm

H₂O: 2% at 100% RH

Stability (CO Analysis)

Automatic Zero at regular intervals, corrects for sample cell contamination, source and detector ageing and pre-amplifier gain changes.

Control Range

CO₂: 0-2,000 $\mu\text{mol mol}^{-1}$ (6 preset levels)

H₂O: 0- Dewpoint (4 preset levels)

Response Time

Electrical: 0.5 seconds

Display/Analog Output: 1.6 seconds

Pneumatic: < 5 seconds

Air Sampling

100 $\text{cm}^3 \text{min}^{-1}$ using an integral DC pump.

RS232 Output

Stored/current data output in standard ASCII format at 1200 baud.

Real Time Clock

Accuracy: Better than 1 min/month at 25^o C.
Operating Temperature: 0-70^o C.

Recording Options

By PC or by the instrument. Automatic logging at user selectable intervals controlled by internal real-time clock.

Power Supply

Internal, rechargeable 12V battery providing up to 8 hours continuous use.

Integral Cuvette Air Supply Unit

300 $\text{cm}^3 \text{min}^{-1}$ measured and controlled by a mass flow meter.

Operating Environment

0-50^o C, non-condensing. In dirty environments, external air filtration is required.

Housing

High impact ABS plastic case.

Dimensions

29 cm W x 12.5 cm H x 20 cm D

Weight

5.2 kg. (including battery)

Leaf Cuvette

Cuvette Materials

The materials of construction are appropriate for the application with respect to water vapor absorption, transparency and heat transfer properties.

Stirring Fan

Provides efficient stirring of cuvette air ensuring rapid measurement.

Cuvette Window

18 mm Diameter (2.5 cm^2)

Air Temperature Sensor (Precision Thermistor)

Range: 0-50^o C

Accuracy: +/- 0.3^o C at 25^o C

PAR Sensor (Cosine Corrected)

Response: 400-700 nm

Range: 0-3,000 $\mu\text{mol m}^{-2} \text{s}^{-1}$

Accuracy: 10 $\mu\text{mol m}^{-2} \text{s}^{-1}$

Optional Light Unit

LED Light Unit providing manual control of cuvette light intensity (0-2,000 $\mu\text{mol m}^{-2} \text{s}^{-1}$)

PP Systems is continuously updating its products and reserves the right to amend product specifications without notice.

**For Further Information, Please
Contact Us At:**

PP Systems
110 Haverhill Rd., Suite 301
Amesbury, MA 01913 U.S.A.

Tel: +1 978-834-0505 Fax: +1 978-834-0545

Email: sales@ppsystems.com

URL: www.ppsystems.com



02/17/11