

Mercury Monitor System MMS

AMBIENT

Automatic Monitoring of Mercury in Air and
other Gases



- Customized solutions
- Monitors 2 to 24 measuring points automatically
- Versions for air, hydrogen and other gases available
- Permanent purging of all sample lines
- Measuring ranges from $0.01 \mu\text{g}/\text{m}^3$ to $2000 \mu\text{g}/\text{m}^3$ Hg
- Software for data acquisition, data visualisation and storage
Sample dilution for high concentrations
- Automatic Calibration Module

Applications

- Chlor-alkali plants with mercury cells
- Metallurgical industry
- Fluorescent lamp production or recycling
- Battery recycling plants
- Contaminated sites
- Hydrogen production plants
- Laboratories or processing plants working with mercury
- Natural gas industry: see brochure for natural gas systems



Function

Sample gas is continuously drawn from each sampling point through special tubing to a heated multiplexer valve unit. One sample at a time is fed into the Mercury Vapor Monitor VM-3000 where the mercury concentration is measured. All sample lines are permanently purged with sample gas thus minimizing the response time of the system. This method allows for sample line lengths of 100 meters and more.

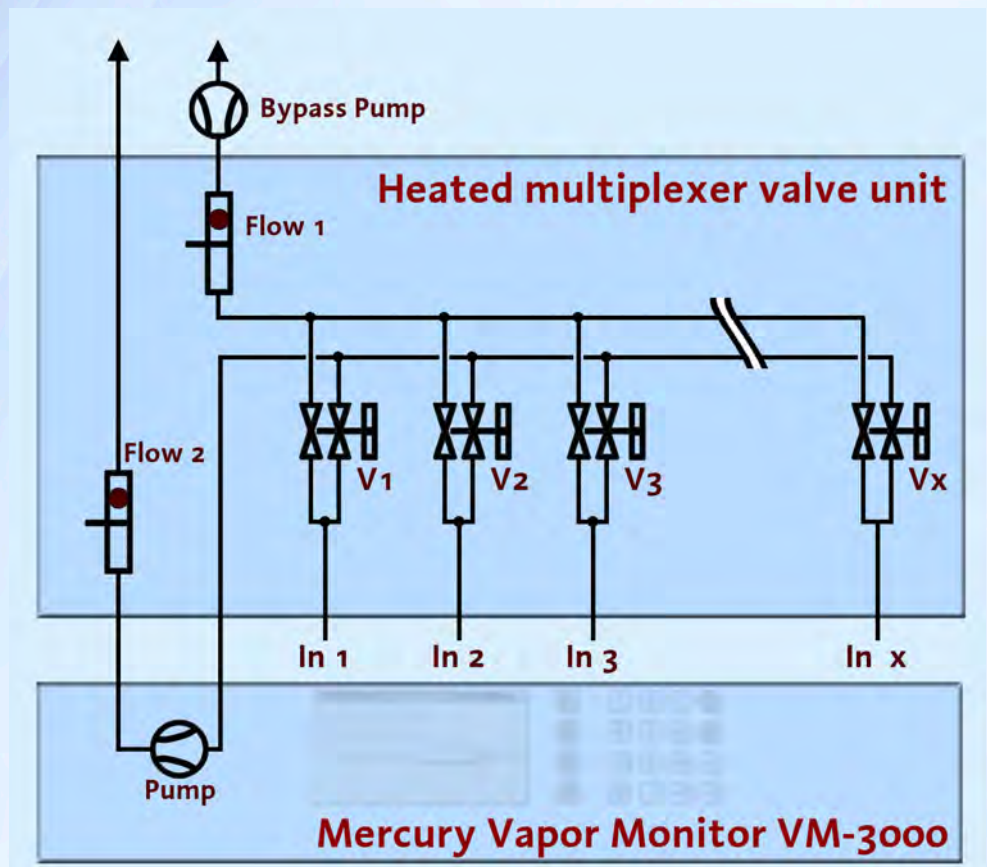

System design

The MMS system basically comprises a multiplexer-valve unit and the highly accurate and selective mercury detector VM-3000 Vapor Monitor. A bypass pump maintains a steady flow of sample through the sample filters, sample lines and multiplexer valves. Flow meters with optical alarm sensors guarantee that flow rates are stable. All components are installed inside a protective cabinet.

A special version employing the UT-3000 Mercury Ultratracer as detector is available for concentrations in the sub- $\mu\text{g}/\text{m}^3$ range.

Options like air conditioning assure reliable function of the system even under extreme climatic conditions.

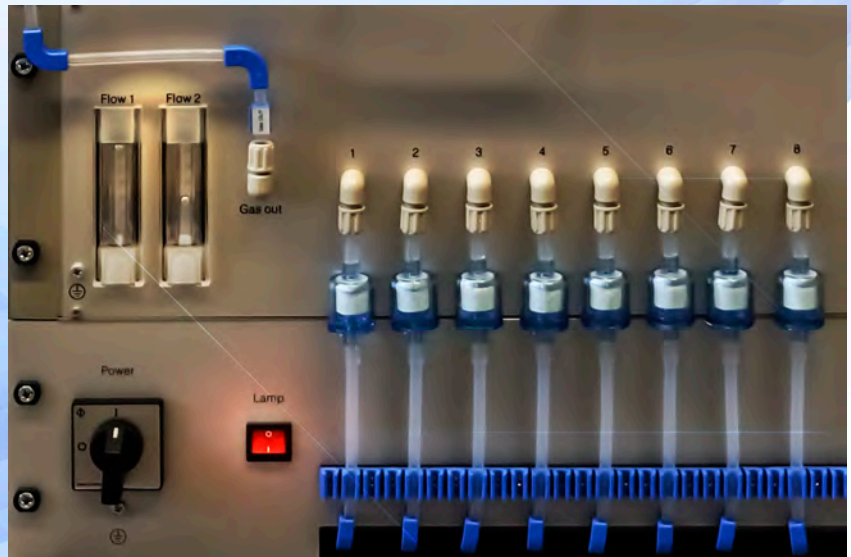

Data output

The analyzer unit can be connected to a PC with a serial cable or optionally with a fibre optic cable for operation under harsh industrial conditions.

Modbus or ethernet communication is available.

Stand-alone operation without PC connection is also possible.

Storage of measuring data

Measurement data are stored on hard disk as ASCII- and EXCEL files. Filed data can be retrieved at any time as graphic diagrams. A friendly search function enables the user to quickly find data of selected time intervals or data exceeding a threshold value.

Self diagnosis of the system

The MMS software permanently checks the status of the system. Low flow of bypass stream or sample, plugging up of sample filters and photometer malfunctions are detected by the system and an error message is displayed. An optional calibration module allows for automatic calibration checks and re-calibrations of the system. The calibration gas is generated by mercury vapor saturation of air and automatic dilution. The mercury filling of the calibrator is sufficient for the entire lifetime of the instrument.



Software and remote control of the analyzer system

The **MMS-Win** software allows remote control of the analyzer-multiplexer system via PC. It provides information to the operator such as: mercury concentrations for each sample point, history of measurement results for each sample point, status of the system and calibration information.

Alarm thresholds, duration of measurement for each channel, zero adjustment, specific deactivation of measuring points, can be controlled by PC.

The operator can interrupt any running measurement and select a sample point for immediate measurement. It is also possible to deactivate any sample point. Emission reports are created automatically and stored as *.txt and *.xls (EXCEL) files.

Main window of **MMS-Win** with position of sampling points

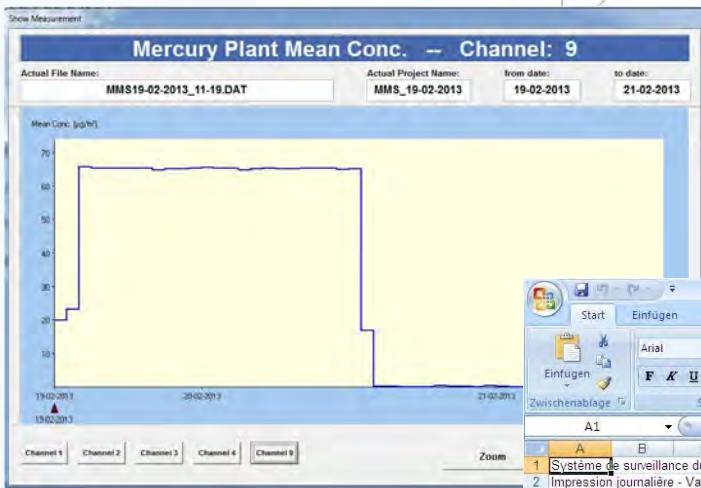
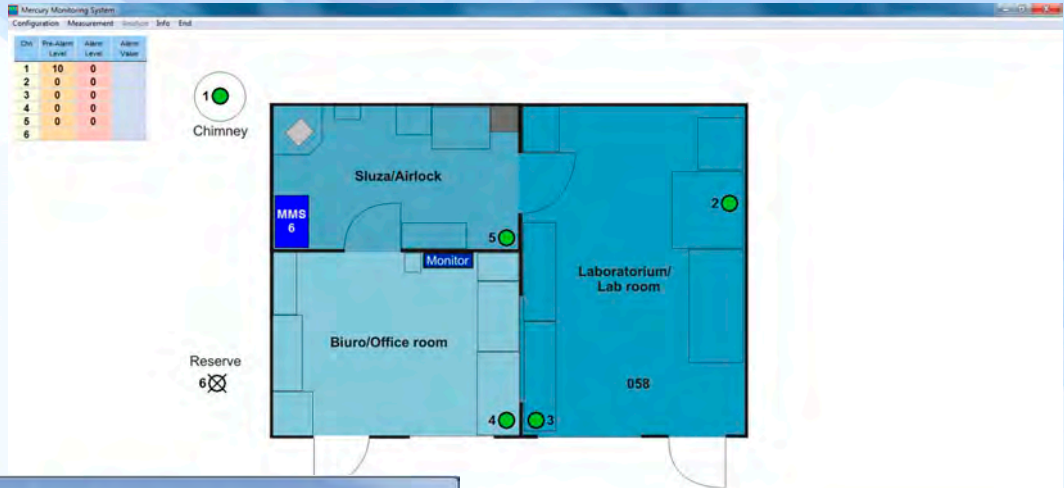

Example: Time course of mean Hg-concentration channel 9

Heure	Point de mesure 1 µg/m³ statut	Point de mesure 2 µg/m³ statut	Point de mesure 3 µg/m³ statut	Point de mesure 4 µg/m³ statut	Point de mesure 5 µg/m³ statut	Point de mesure 6 µg/m³ statut
01:00	0.1	0.1	0.1	0.0	0.0	0.0
02:00	0.0	0.0	0.0	0.0	0.0	0.0
03:00	0.1	0.1	0.1	0.1	0.0	0.0
04:00	0.1	0.1	0.1	0.1	0.0	0.0
05:00	0.1	0.1	0.0	0.0	0.0	0.0
06:00	0.0	0.0	0.0	0.0	0.0	0.0
07:00	0.0	0.0	0.0	0.0	0.0	0.0
08:00	0.1	0.1	0.1	0.1	0.1	0.1
09:00	0.2	0.2	0.2	0.2	0.1	0.1
10:00	0.2	0.1	0.1	0.1	0.0	0.0
11:00	0.1	0.0	0.1	0.0	0.0	0.0
12:00	0.0	0.0	0.0	0.0	0.0	0.0
13:00	0.1	0.0	0.0	0.1	0.0	0.0
14:00	0.1	0.1	0.0	0.1	0.0	0.0
15:00	0.1	0.0	0.1	0.0	0.0	0.0
16:00	0.4	0.5	0.4	0.5	0.4	0.3
17:00	1.5 maximale	1.4 maximale	1.5 maximale	1.5 maximale	1.3 maximale	1.4 maximale
18:00	1.0	0.8	0.8	0.8	0.7	0.8
19:00	0.3	0.1	0.1	0.2	0.0	0.0
20:00	0.1	0.1	0.1	0.1	0.0	0.0
21:00	0.1	0.0	0.0	0.0	0.0	0.0
22:00	0.0	0.0	0.0	0.0	0.0	0.0
23:00	0.1	0.1	0.1	0.1	0.0	0.0
24:00	0.2	0.1	0.1	0.1	0.0	0.0
Moyenne						
Quotidienn	0.2	0.2	0.2	0.2	0.1	0.1
Standard						
Ecart	0.3	0.3	0.3	0.3	0.3	0.3

Measurement data displayed in EXCEL



Setting of alarm thresholds

Benefits of the Mercury Monitoring System MMS

- low maintenance demand
- no sensitivity for water vapor
- high stability of calibration
- quick response time
- customized software
- minimized memory effect



Technical Specifications Mercury Monitoring System MMS

Multiplexer module	
Number of sample points	2 ... 24
Purging of sample lines:	continuously, approx. 40 - 80 l/h for each channel
Flow control:	Flow meters with alarm sensors for low flow
Heating of valve unit:	approx. 70 °C
Measuring duration:	45 sec - 99 minutes, separately adjustable for each channel
Detector	
Measuring principle:	Cold Vapor Atom Absorption Spectrometry (CVAAS) Wavelength: 253.7 nm
Principle of preconcentration: (only special version with UT-3000)	Amalgamation on gold surface, thermal desorption by rapid heating (MI GoldTrap)
Measuring ranges: (standard version with VM-3000)	0,1 - 100 µg/m ³ 1 - 1000 µg/m ³ 1 - 2000 µg/m ³
Measuring range: (special version with UT-3000)	0,01 - 50 µg/m ³
Sample flow:	approx. 80 l/h per channel
Signal output:	analogue: 4-20 mA serial: RS 232 Modbus RTU (optional) Ethernet (optional)
Construction, weight and Dimensions	
Cabinet:	metal, protection standard IP 55 (NEMA 4X, others as an option)
Dimensions:	from 553 x 600 x 500 mm (WxHxD) to 800 x 2000 x 600 mm; according to number of channels and optional equipment (air conditioning)
Weight:	approx. 35 - 175 kg; depending on number of channels and optional equipment
Software	
System requirements:	PC with Windows XP or higher
Display of measuring data:	current readings numerically, filed data as concentration-time graphs

The Challenge: Mercury Analysis The Response: ENVEA GmbH

Even nowadays quantitative trace analysis of mercury is still a challenging task for the analyst. ENVEA GmbH is at all times striving to develop leading edge products for mercury analysis at the highest technical level.

The range of applications for our mercury analyzers is unique world-wide.



ENVEA GmbH
Analytical Technologies
Liebigstraße 5
D-85757 Karlsfeld
mail.mi@envea.global
Tel.: +49(0)8131 - 50 57 20
Fax.: +49(0)8131 - 50 57 22

ISO
9001

As a leading supplier of high precision analytical equipment, we strive at all times to offer top quality solutions. Our products are manufactured according to the ISO 9001 quality regulations.



ENVEA (Headquarters)
111 Bd Robespierre / CS 80004
78304 Poissy CEDEX 4 - FRANCE
+33(0)1 39 22 38 00
info@envea.global



Visit us at:
www.envea.global

