



PURELAB[®] Quest

Technical Specification

DEDICATED TO DISCOVERY

The **perfect solution** for all your **laboratory needs**

PURELAB® Quest offers you the most advanced, affordable water specification available today, delivering all three types of lab water directly from tap water input.

The Complete Water Specification

Whether you require ultrapure (Type I) water for high performance liquid chromatography (HPLC) & molecular biology techniques; pure water (Type II) for media preparation & general chemistry or RO (Type III) water for glassware washing & autoclaves; PURELAB **Quest** dispenses water for the widest range of applications in a single elegant system.

Reliable

PURELAB Quest has multiple quality sensors to constantly monitor both ultrapure and pure water; inbuilt periodic recirculation to minimise biofilm build up and optional point of use filters. It uses tried and tested core components from over a decade of user experience and has been robotically tested to achieve more than 150,000 dispensing cycles.

Space Saving Design

Measuring at only 232mm in width, the compact design can be wall mounted or placed on a bench to easily fit into any laboratory - optimising valuable lab. space.

Reduced Environmental Impact

PURELAB Quest is made from more than 85%* reclaimed materials. It is designed to reduce the environmental impact of your laboratory.

Simple

PURELAB Quest is simple to install, operate and has a pre-programmed annual sanitisation process to minimize downtime.

Data Capture

With PURELAB Quest, data capture is via a USB port which is useful for capturing water parameters, software updates & diagnosing certain faults/issues. Quest is also IOT enabled with **AQUAVISTA** from Veolia.

Flow process PURELAB® Quest UV

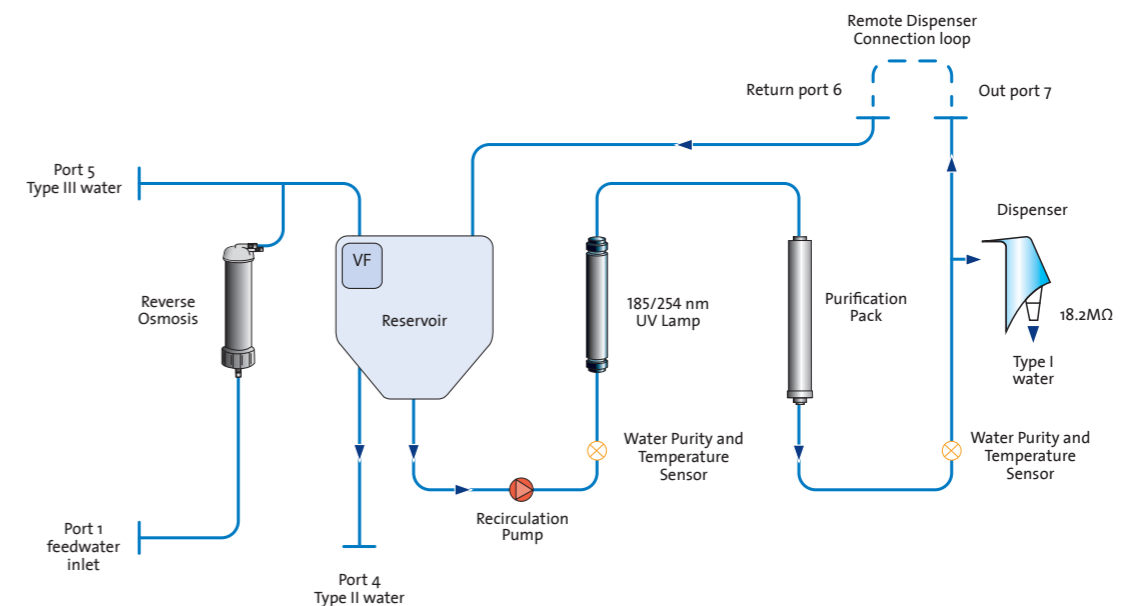

* Materials not in contact with purification process



Type I, II & III Water

KEY FEATURES

- Tap to Ultrapure, Pure & RO water
- Multiple water purity sensors
- Fully recirculating
- 232mm in width
- Bench top or wall mounted
- Data Capture and IoT with AQUAVISTA from Veolia

IDEALLY SUITED FOR :

- Liquid Chromatography
- Mass Spectrometry
- Atomic Spectroscopy
- Molecular Biology
- Immunochemistry
- Media/Buffer preparation
- Autoclaves
- Washing / Rinsing
- Hydroponics



Water Specification

International conformity

Technical Specifications	PURELAB® Quest UV	PURELAB® Quest
Ultrapure (Type I) water specifications (from fixed dispense point)		
Resistivity	18.2 MΩ.cm @ 25°C	18.2 MΩ.cm @ 25°C
Dispense flow rate	Up to 1.2l/min	Up to 1.2l/min
TOC	<5 ppb	<30 ppb
Bacterial TVC	<0.1 cfu/ml*1	<0.1 cfu/ml*1
Endotoxin	<0.001 EU/ml*2	<0.001 EU/ml*2
RNases	<1pg/ml	N/A
DNases	<5pg/ml	N/A
pH	Effectively Neutral	Effectively Neutral
Particulates	0.2µm filtration*1	0.2µm filtration*1
Recommended daily volume	Up to 10l/day*3	Up to 10l/day*3
Pure (Type II) water specifications (Outlet port 4)		
Resistivity	> 1 MΩ.cm @ 25°C	> 1 MΩ.cm @ 25°C
TOC	<50 ppb	<50 ppb
Bacterial TVC	<100 cfu/ml	<100 cfu/ml
Recommended daily volume	Up to 10 l/day*3	Up to 10 l/day*3

Water Specification

International conformity

Technical Specifications	PURELAB® Quest UV	PURELAB® Quest
RO-permeate (Type III) water specifications (Outlet Port 5)		
Conductivity	<20 µS/cm*4	<20 µS/cm*4
TOC	<200 ppb*4	<200 ppb*4
Bacterial TVC	<1000 cfu/ml*4	<1000 cfu/ml*4
Ionic rejection	>96%*5	>96%*5
Particulates and Bacteria rejection	>99%	>99%
Organic rejection (MW > 200 Da)	>99%	>99%
Production flow	10l/hr*5	10l/hr*5
Daily volume	Up to 30l/ day	Up to 30l/ day

Feedwater Specifications

Water Source	(Potable Water Source)
Conductivity	<2000 µS/cm (High conductivity feedwaters may lower purification pack life and raise Type III water conductivity)
Hardness	<350 ppm as CaCO ₃
Free Chlorine	<0.05 ppm Cl ₂
Chloramine	<0.02 ppm Cl ₂
Total Chlorine	<0.05 ppm Cl ₂
Silica	<30 ppm SiO ₂
Carbon Dioxide (CO ₂)	<30 ppm (Recommended <20 ppm)
Fouling Index	<10
Iron/Manganese	<0.5 ppm Fe/Mn
TOC (Total Organic Carbon)	Recommended <2ppm

Environment

Temperature	4–40°C (Recommended 10–25°C)
Humidity	Non-condensating. Humidity Max 80%
Surroundings	Clean laboratory environment

*1 When using point of use filters (LC134/LC145/LC197)

*2 When using point of use filter(LC197)

*3 Available volume of Type I and II water combined; increased use will reduce purification pack life

*4 Subject to suitable feedwater purity (see ionic rejection) and system maintenance

*5 With feedwater pressure at > 4 bar and temperature at 15°C

Feedwater Pressure and Flow Rates

Feedwater Flowrate	Up to 75L/hr
Mains Drain Requirements	> 90L/hr
Minimum Inlet Pressure	2 bar (30 psi)
Maximum Inlet Pressure	6 bar (30 psi)
Optimum Inlet Pressure	Regulate to 4 bar (LA512)

Pipe Connections

Inlet	8mm (5/16) OD Tube
Outlet	8mm (5/16) OD Tube
Drain	8mm (5/16) OD tube
Reservoir Outlets	8mm (5/16) OD tube
Reservoir Overflows	8mm (5/16) OD tube

Technical Specifications

Electrical Requirements

Technical Specifications	PURELAB® Quest UV	PURELAB® Quest
Main Input	100-240VAC, 50–60Hz	100-240VAC, 50–60Hz
Power Required	24 V DC	24 V DC
Power Consumption	120 VA	120 VA
Noise Output	dBA - <40	dBA - <40

Installation

Worktop	✓	✓
Wall-mounted	✓	✓

Dimensions and Weights

Dispatch Weight	19.6kg	18.5kg
Operational Weight	23kg	21.4kg
Dimensions	Height 510mm (20.07") Weight 232mm (9.133") Depth 421mm (16.57")	Height 510mm (20.07") Weight 232mm (9.133") Depth 421mm (16.57")

Dedicated to Discovery

info@elgalabwater.com / www.elgalabwater.com

ELGA Labwater are specialists in the engineering, service & support of water purification systems.

Unrivalled product design has achieved international recognition and awards.

Worldwide technical service teams support science & healthcare globally with specialist expertise.

Global digital performance monitoring from AQUAVISTA ensures laboratory work is uninterrupted.

A global supply chain supports clients from regional centres on every continent.

To find your nearest ELGA representative, go to www.elgalabwater.com and select your country for contact details.

Elga Global Operations Centre.

tel: +44 (0) 203 567 7300

fax: +44 (0) 203 567 7205



OVER 70 INTERNATIONAL PATENTS